

Rec'd 6/5/2024

Pittsfield Lawn & Tractor Inc.

1548 W. Housatonic St.

Pittsfield MA 01201

Re: Town of New Lebanon Highway Dept. Excavator/Trailer bid

To: New Lebanon Town Board

Pittsfield Lawn & Tractor Inc. is pleased to offer the following items for bid consideration:

2023 Yanmar Vio50-6A compact excavator serial #YMRVIO50JPAJ62281 with under 500 hours.

Original MSRP in 2023 \$102,037.00

This unit is equipped with all standard equipment (see attached spec sheet) plus the following options:

ROPS certified cab enclosure with heat & a/c, hydraulic thumb, 24" digging bucket and 42" grading bucket with bolt on edge, 4 Year/4,000 hour manufacturer's warranty (start date 2/22/2023)

Unit meets or exceeds enclosed bid specs. BID PRICE--\$64,800.00

2016 CAM Superline 6CAM18C equipment trailer serial #5JPBU2328GP040775 GVWR 13,000lbs

Unit is equipped with pressure treated decking, tongue mounted toolbox (lockable), full width ramp gate with spring assist, 12,000lb bolt-on drop leg jack, electric brakes on both axles, sealed wiring harness, rubber mounted LED lights, deck length 18', width between wheel wells 81". Trailer meets or exceeds bid specs. BID PRICE--\$4,950.00

Respectfully Submitted,

Chris Gingras



Pittsfield Lawn & Tractor Inc.

NON-COLLUSIVE BIDDING CERTIFICATE

*Section 103-d of the General Municipal Law requires every bid or proposal made to a political subdivision, or any public department, agency or official, where competitive bidding is required by statute, rule, regulation or local law, to contain a non-collusive bidding certification.*

By submission of this bid, each bidder and each person signing on behalf of any bidder certifies, and in the case of a joint bid each party thereto certifies as to its own organization, under penalty of perjury, that to the best of knowledge and belief:

1. The prices in this bid have been arrived at independently without collusion, consultation, communication, or agreement, for the purpose of restricting competition, as to any matter relating to such prices with any other bidder or with any competitor;
2. Unless otherwise required by law, the prices which have been quoted in this bid have not been knowingly disclosed by the bidder and will not knowingly be disclosed by the bidder prior to opening, directly or indirectly, to any other bidder or any competitor; and
3. No attempt has been made or will be made by the bidder to induce any other person, partnership or corporation to submit or not to submit a bid for the purpose of restricting competition.

**PITTSFIELD LAWN & TRACTOR**  
1548 W. Housatonic St.  
Pittsfield, MA 01201

\_\_\_\_\_  
*Legal Name of Person, Firm or Corporation*

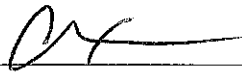
  
\_\_\_\_\_  
*Signature*

*President*  
\_\_\_\_\_  
*Title*

NOTICE TO BIDDERS  
HIGHWAY DEPARTMENT  
TOWN OF NEW LEBANON  
COUNTY OF COLUMBIA

NOTICE IS HEREBY GIVEN that the TOWN OF NEW LEBANON HIGHWAY DEPARTMENT is seeking sealed bids for one (1) **used mini-excavator** with the following specifications:

500 hours or less; 10,000lb machine, a hydraulic thumb; both grading and digging buckets; a progressive 3 stage pump hydraulic system; a hydraulic quick coupler – pin grabber style; an enclosed cab with heat and A/C; cylinder rod guards; and a zero-tail swing.

NOTICE IS HEREBY GIVEN that the TOWN OF NEW LEBANON HIGHWAY DEPARTMENT is seeking sealed bids for one (1) **used 2015 or newer 12,500 GVW equipment trailer** with a toolbox in the tongue of the trailer, and full width ramps with spring assist.

Bids MUST be in a SEALED, PLAIN WHITE ENVELOPE (no logo); marked "EXCAVATOR/TRAILER BID;" include a NON-COLLUSIVE BIDDING CERTIFICATION and received in the office of the Town Clerk at the New Lebanon Town Hall, 14755 Route 22, New Lebanon, NY, no later than 4:00PM. on FRIDAY, JUNE, 7TH, 2024.

The bids will be opened at the office of the Town Clerk at 4:00pm. on FRIDAY, JUNE 7TH, 2024. Bids will be reviewed by the Highway Superintendent and the New Lebanon Town Board at the Regular Town Board Meeting at the New Lebanon Town Hall, 14755 State Route 22, New Lebanon, NY at 6:00pm. on June 11th, 2024. The Town Board reserves the right to accept or reject any or all bids.

Peter McCagg  
Highway Superintendent  
5/16/2024

## QUICK SPECS

Weight (Cabin)	10,792 lbs
Horsepower	39 HP
Max Dig Depth	12'3"

**Best performance by your side for the really tough jobs.**



## ViO50-6A

**POWERFUL, EFFICIENT  
39 HP TIER 4 FINAL  
YANMAR DIESEL ENGINE**

**VIO PROGRESSIVE  
3-PUMP HYDRAULIC  
SYSTEM (VIPPS)**

**EASY-TO-OPERATE  
JOYSTICK CONTROLS  
WITH ARMRESTS  
REDUCE OPERATOR  
FATIGUE**

**SPRING STEEL  
CYLINDER ROD GUARDS  
AND HOSE PROTECTION**

**4-PILLAR ROPS/FOPS  
CANOPY FOR SAFETY**

**INTEGRATED BOOM  
LIGHT PROTECTS FROM  
DAMAGE**

**EASY MAINTENANCE  
ACCESS TO EVERY  
MAJOR COMPONENT**

**ANGLED CRAWLER  
FRAME REDUCES  
FOREIGN MATTER  
BUILD-UP**

**OPTIONAL PTO2  
CIRCUIT AVAILABLE**

**OPTIONAL ENCLOSED  
CAB WITH HEAT & A/C**

YANMAR's ViO50-6A, our 5-ton class mini excavator, is powered by a 39 HP Tier 4 Final YANMAR engine. It comes packed with features to provide high work efficiency and operator comfort while working on tough construction job sites. With true zero tail swing, it allows you to be more productive to trench and dig with low total cost of ownership. Plus, YANMAR's unique SmartAssist Remote gives you peace of mind with theft prevention and maintenance management tools as well as other remote monitoring services.

## INNOVATIVE FEATURES



### True Zero Tail Swing

Our true zero tail swing technology means no part of the housing extends beyond the tracks. Since the entire machine operates within its tracks, you can work efficiently almost anywhere, with less damage to the machine and the worksite.



### YANMAR's Patented Hydraulic Quick Coupler

The standard hydraulic quick coupler makes changing buckets fast and easy. With the exception of fitting and removing the safety lock pin, the entire operation is performed electronically while you're seated in the comfort of the cab. Less hassle. Less downtime. More productivity.



### A Cab With Everything At Your Fingertips

The ViO50-6A comes standard with ECO Mode, Auto-Decel Mode, lever-controlled backfill blade and 2-speed operation incorporated right into the operator's station. Plus, you get an innovative LCD monitor, showing key operating information and maintenance notification intervals.





# ViO50-6A

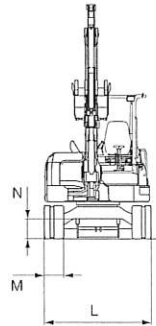
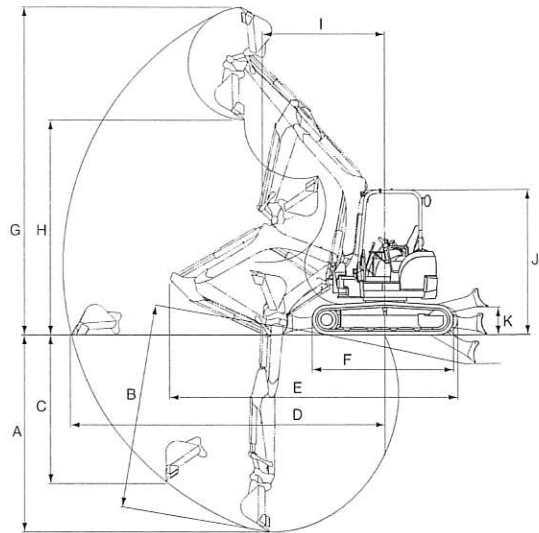
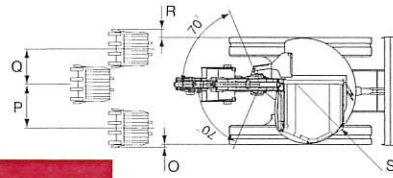

## Dimensions - ViO50-6A

<b>A</b> 11'8" (3,550 mm)	<b>K</b> 1'8" (500 mm)
<b>B</b> 12'3" (3,740 mm)	<b>L</b> 6'4.5" (1,940 mm)
<b>C</b> 7'10" (2,380 mm)	<b>M</b> 1'2" (350 mm)
<b>D</b> 18'10" (5,740 mm)	<b>N</b> 1'1.6" (345 mm)
<b>E</b> 17'5" (5,320 mm)	<b>O</b> 1.5" (35)
<b>F</b> 8'6" (2,590 mm)	<b>P</b> 2'3" (680 mm)
<b>G</b> 18'8" (5,700 mm)	<b>Q</b> 2'6" (770 mm)
<b>H</b> 12'1" (3,680 mm)	<b>R</b> 5" (125 mm)
<b>I</b> 7'10" (2,380 mm)	<b>S</b> R3'2" (R970 mm)
<b>J</b> 8'4" (2,540 mm)	

## Specifications

Model			ViO50-6A	
Type			Canopy	Cabin
Operating Weight	Rubber Track	lbs (t)	10,417 (4.73)	10,792 (4.90)
	Steel Track	lbs (t)	10,703 (4.86)	11,078 (5.03)
Engine	Type	-	Vertical 4-cylinder water-cooled direct injection diesel engine	
	Model	-	YANMAR 4TNV88C-PBV	
	Output	HP (kW)/rpm	39 (29.1) / 2,400	
Performance	Max Digging Force, Bucket / Arm	lbs (kN)	8,206 (36.5)* / 5,103 (22.7)*	
	Traveling Speed, High / Low	MPH (km / h)	2.9 / 1.5 (4.6 / 2.4)	
	Swing Speed	RPM	10	
	Boom Swing Angle, (L / R)	degrees	68° / 68°	
Ground Contact Pressure	Rubber Track	PSI (kPa)	4.25 (29.3)	4.41 (30.4)
	Steel Track	PSI (kPa)	4.42 (30.5)	4.58 (31.6)
Hydraulic System	Pump Capacity	GPM (L / min)	11.2 + 11.2 + 9.7 + 2.8 (42.5 + 42.5 + 37 + 10.8)	
	Main Relief Set Pressure	PSI (MPa)	3553 x 2 + 3133 + 566 (24.5 x 2 + 21.6 + 3.9)	
Undercarriage	Track Type	-	Rubber or Steel	
Blade Dimensions	Width x Height	ft-in (mm)	6'6" x 14" (1,970 x 400)	
Fuel tank capacity		Gals (L)	17.4 (66)	

\*without quick coupler

## Standard Equipment

- Blade
- Boom Swing
- Rubber Tracks
- Hydraulic Quick Coupler\*
- 2-way Pattern Control
- Arm End Auxiliary Valve
- Cylinder Rod Guards (boom, arm, bucket, blade)
- ROPS / FOPS Cabin or Canopy
- Windshield Washer (cabin spec)
- Defroster (cabin spec)
- Joystick Pilot Controls
- Arm Rests (adjustable)
- Suspension and Reclining Seat
- Seat Belt
- Traveling Levers and Pedals
- Traveling Alarm
- Built-in Boom Light
- Exterior Canopy or Cabin Work Light
- Operation Manual

\*Also available without Quick Coupler.

Please note that the standard equipment may vary from this list. Consult your YANMAR dealer for confirmation.

## Hydraulic PTO

Model	ViO50-6A		
	Output	PSI (MPa)	GPM (L / min)
			2,200RPM
Combined Flow, Double Actions	3,553 (24.5)	20.9 (79.5)	11.4 (43.4)

## Lifting Capacity

LIFT POINT HEIGHT in (mm)	(R) LIFT RADIUS in (mm)											
	RATED LIFT CAPACITY OVER END BLADE DOWN lbs (kg)				RATED LIFT CAPACITY OVER END BLADE UP lbs (kg)				RATED LIFT CAPACITY OVER SIDE BLADE DOWN lbs (kg)			
	MAX	157.5 (4,000)	118.1 (3,000)	78.7 (2,000)	MAX	157.5 (4,000)	118.1 (3,000)	78.7 (2,000)	MAX	157.5 (4,000)	118.1 (3,000)	78.7 (2,000)
157.5 (4,000)	2,403 (1,090)				2,290 (1,040)				1,763 (800)			
118.1 (3,000)	2,358 (1,070)	2,314 (1,050)			1,543 (700)	1,829 (830)			1,322 (600)	1,587 (720)		
78.7 (2,000)	2,425 (1,100)	2,645 (1,200)	3,306 (1,500)		1,300 (590)	1,719 (780)	3,152 (1,430)		1,146 (520)	1,587 (720)	2,425 (1,100)	
39.4 (1,000)	2,535 (1,150)	3,042 (1,380)	4,365 (1,980)		1,256 (570)	1,675 (760)	2,535 (1,150)		1,124 (510)	1,499 (680)	2,204 (1,000)	
Ground (0)	2,579 (1,170)	3,284 (1,490)	4,585 (2,080)	6,459 (2,930)	1,300 (590)	1,587 (720)	2,358 (1,070)	4,166 (1,890)	1,102 (500)	1,366 (620)	2,028 (920)	3,351 (1,520)
-39.4 (-1,000)	2,667 (1,210)	2,910 (1,320)	4,232 (1,920)	6,393 (2,900)	1,521 (690)	1,587 (720)	2,403 (1,090)	4,387 (1,990)	1,322 (600)	1,344 (610)	1,984 (900)	3,571 (1,620)
-78.7 (-2,000)	2,535 (1,150)		2,954 (1,340)		2,601 (1,180)		2,469 (1,120)		1,940 (880)		2,116 (960)	